



Hydro-Optic Disinfection™ Solutions



The RZ104 series

Atlantium's new modular UV based disinfection system

Best microbial results vs. any other system, thanks to our patented design – Total Internal Reflection

Fully automated dose control – for varying water conditions

Online lamp and UVT monitoring makes sure what you see is what you get – always



Atlantium brings UV disinfection to new levels of effectiveness. Third party validation according to USEPA protocol achieves more than 5 log reduction of microbes.

Total Reliability.

Environmentally friendly solution, reduces chemical usage, energy and water waste.

The Hydro Optic Disinfection Advantages

Uniform UV dose distribution – Unparalleled disinfection performance – hydraulic properties and UV light patterns ensure all microorganisms in the system’s quartz disinfection chamber receive a uniform UV dose, achieving consistently high levels of microbial inactivation (see Figure 1).

- **Minimal head loss and unimpeded water flow** – inline system provides water with smooth and obstacle free disinfection chambers (see Figure 2). There are no brushes to break down or baffles to accumulate biofilms.

Atlantium’s proprietary medium pressure high intensity UV lamp – ensures broad spectrum germicidal UV output for maximum effectiveness.

Real-time control and monitoring – Required dose is automatically adjusted based on continuous, real-time measurement of lamp intensity, water flow and UV transmissivity; water consistently receives the required dose and uses less energy than the traditional setpoint systems.

- **Tracking & reporting** – Logging capabilities – logs and records dose, UV transmissivity, water flow and lamp intensity data in real time. The system generates reports with the touch of a button.

- **UV dose displayed is the actual dose delivered** – system displays validated dose (RED) required for the inactivation goal.

Operation & Maintenance - Quick and easy! System designed to significantly reduce maintenance and down time.

- **Temperature** independent operation.
- **Continuous ultrasonic cleaning** – deters deposit formation.
- **Reduced Cleaning in Place cycles** – as a result of decreased deposits in the disinfection tube.

Calculated UV Dose Probability Density Functions*

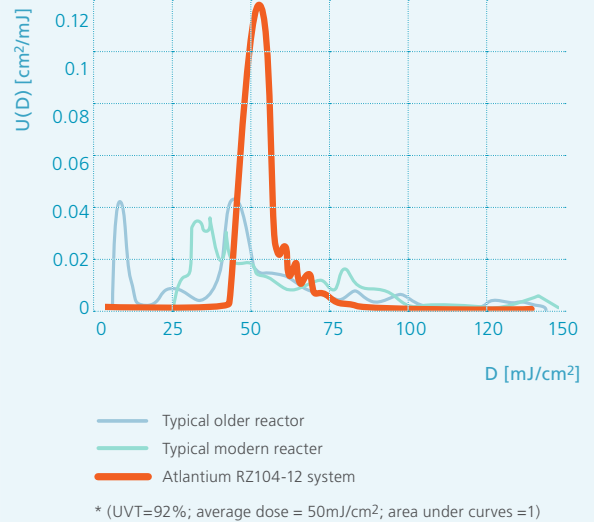

Figure 1: The RZ104-12 is characterized by a very narrow dose distribution histogram; inactivation of all targeted pathogens at the required dose is achieved with high energy-efficiency, especially at high dosages. In contrast, the broad dose distribution of the other reactors indicates that many microbes are receiving a lower than required dose; increasing the dose to achieve higher inactivation requires greater expenditure of energy.

RZ-Series – Modular. Configure the best system for your needs

Atlantium’s latest implementation of Hydro-Optic Disinfection™ technology, the RZ Series, offers an easily integrated, modular system that is a great fit for a broad range of applications and disinfection requirements. Flexible configuration enables Atlantium to provide customers with precisely the system they need to achieve their goals.



Screens display the status of all the relevant system parameters in real-time and show the precise UV dose (RED) being delivered at any given moment.

Sample selection of RZ104 models and specifications

(Additional models to meet other flow rates requirements and specific applications available)

Type	Lamps*	Max Power consumption** kW	Flow Rate *** m ³ /h	Flange Ø	↕ → ↗ (with ultrasound)	Weight (with ultrasound)
					Mm/In	Kg/Lbs
RZ104-11	1 x 1.0 kW	1.0	38	DN100 PN16 DIN 2576 ANSI B 16.5 class 150 Tri-clamp available	405-1039-326 16-41-12.8	41 / 90
RZ104-12	2 x 1.0 kW	2.0	76	DN100 PN16 DIN 2576 ANSI B 16.5 class 150 Tri-clamp available	405-1565-325 16-62-12.8	66 / 145
Electric Cabinet RZ104-11					764-840-355 30-33-13.3	45 / 99
Electric Cabinet RZ104-12					1090-853-340 43-34-13.25	130 / 286

* UV light source: MPHI UV lamps; typical relative drive: 75%

** Power consumption varies according to dose; control system automatically adjusts power consumption from 40% to 100% based on real-time measurement of water's flow rate and UVT

*** Flow rate at UVT=90%, RED=40mj/cm², end of lamp life

All Models

Additional equipment	A complete set of accessories can be purchased separately from Atlantium. A flow switch/flow meter is required with every system.
Disinfection chamber material	High grade fused silica (Quartz)
Housing material	St. St. 316L
Controller	Internal, with flat touch screen user interface; remote monitoring and control capability
Design pressure	145 psi (10 Bar); PN 10 is at 20°C
Environmental temperature	0°C to 70°C (32°F - 158°F)
Operating temperature (water)	4°C to 50°C (39.2°F to 104°F)
Operating temperature (electrical cabinet)	0°C to 55°C (32°F to 131°F)
Electrical requirements	115/200/230/400/440/480 VAC. 1 phase for 163-11 and 163-12, 3 phase for all other combinations.

Regulatory Compliance

- The system complies with the European Low Voltage Directive (LVD), 73/23/EEC for electrical safety
- Council Directive 98/83/EC of 3 November 1998 for the quality of water intended for human consumption
- Biocompatible materials used in any body part that is in contact with water (for avoidance of irritation, sensitization and toxicity)
- CE compliant

Why Hydro-Optic Disinfection technology is so effective

Atlantium's innovative technology adapts the principle of Total Internal Reflection to reinvent ultraviolet (UV)-based disinfection of water. The core of the system is a disinfection chamber made of quartz and surrounded by an air block. This configuration helps trap the UV light's rays [from customized medium-pressure high-intensity (MPHI) UV lamps] and forces them to repeatedly bounce inside the disinfection chamber – giving the light a longer path in which to disinfect all target microbes in the chamber. Microbes receive the required UV dose in a uniform manner wherever they are located, leading to very high levels of microbial inactivation.

Pressure Drop as a Function of Flow Rate in the RZ104

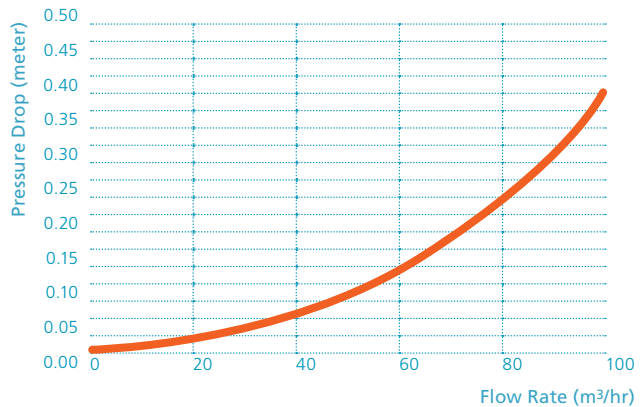

Low head loss is an important RZ104 feature

Figure 2

Industrial / Commercial Applications

(for higher flow applications, see the RZ163 Series datasheet)

Aquaculture
 Flow-through protection
 Re-circulation protection
 Aquariums*

* suitable for fresh or sea water

Food & Beverage
 Product water disinfection
 Firewall
 Chlorine replacement
 Post-GAC filter disinfection
 Membrane protection
 Ozone destruction
 Ozone replacement
 Process water disinfection
 Firewall
 Chlorine replacement
 Cooling tower disinfection

Dairy
 Product water disinfection
 Firewall
 Chlorine replacement
 Post-GAC filter disinfection
 Membrane protection
 Ozone destruction
 Ozone replacement
 Process water disinfection
 Firewall
 Chlorine replacement
 Cooling tower disinfection

Pools & Spas
 Chloramine reduction
 Pool water disinfection

Pharmaceutical
 Product water disinfection

Horticulture
 Firewall
 Membrane protection

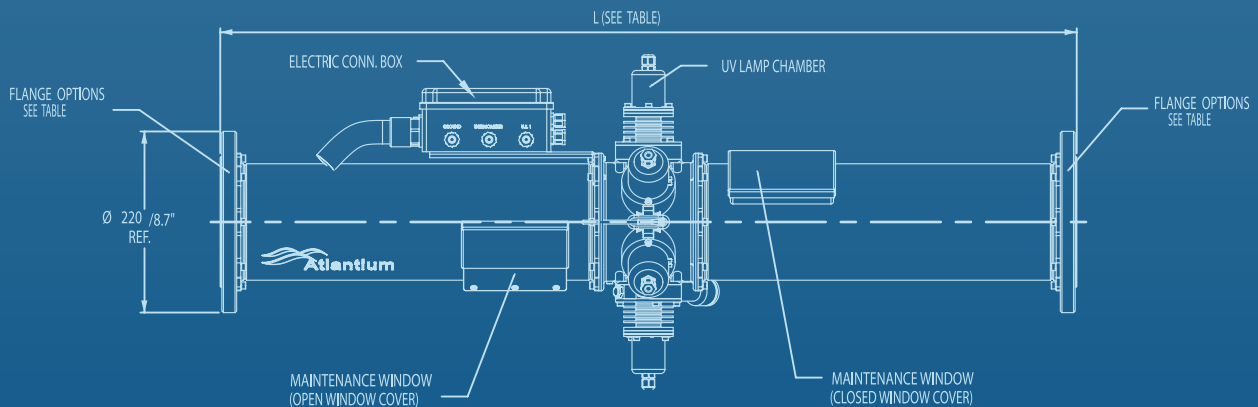

Atlantium Technologies Ltd.
 Har Tuv Industrial Park POB 11071 Bet Shemesh 99100 ISRAEL
 Tel: +972 2 992 5001 Fax: +972 2 992 5005
 sales@atlantium.com

www.atlantium.com

