

HYTROL CONVEYOR COMPANY, INC.

Model 138-NSPC

- 4 Bed Widths
- Slave Driven from Model 138-NSP
- Adjustable LS-Type Floor Supports Available

The 138 Spool Curves and Spurs are designed to be slave driven from the 138-NSP Conveyor. Curves are used where turns in the conveyor line are necessary. Spurs are used in diverging and converging applications.

Between Rail Width	Overall Frame Width	"R"	Number of Rollers				WEIGHTS (Lbs.)			
			90°	60°	45°	30°	90°	60°	45°	30°
10"	12"	25"	28T/8S	20T/8S	14T/24S	10T/24S	178	150	163	138
13"	15"						225	181	190	158
16"	18"						237	190	202	167
22"	24"	32 1/2"	36T/8S	26T/8S	18T/24S	13T/24S	256	200	219	182

All weights in catalog are conveyor weights only. Accessories, crating, etc., are not included.

T = TAPERED
S = STRAIGHT

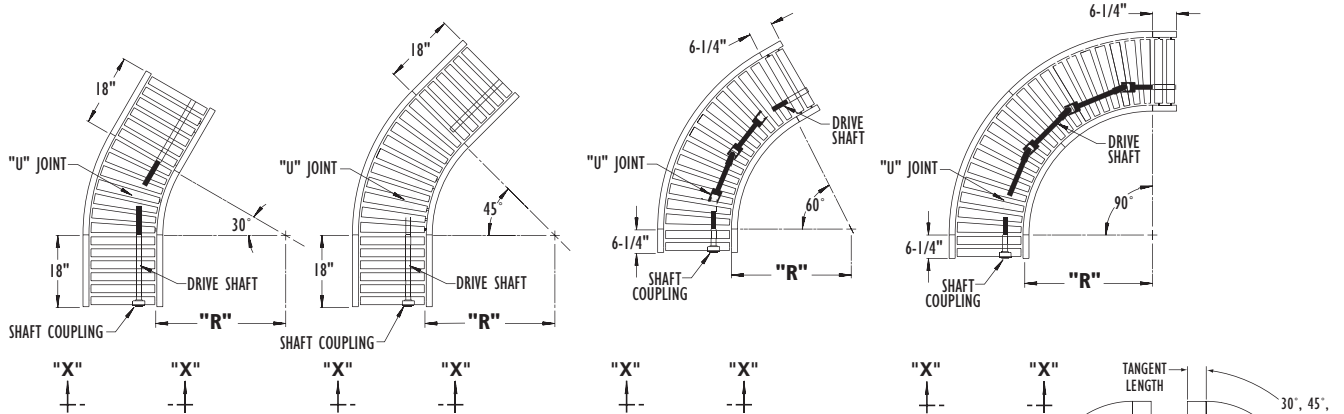

NOTE: DARK SHAFT INDICATES POSITIVE DRIVE SPOOLS.

• CURVE WITH OPTIONAL DRIVE SPECIFY RH OR LH

LIVE ROLLER

Model 138-NSPS

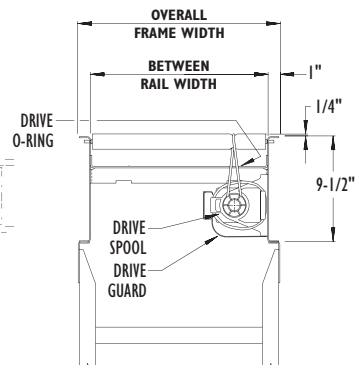
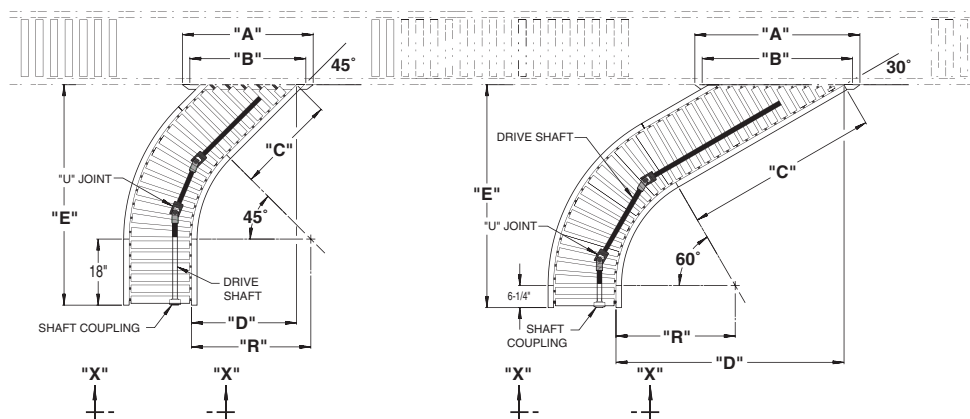

SECTION "X-X"

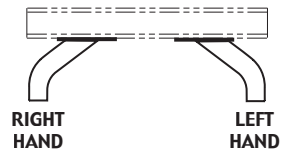

Between Rail Width	Overall Frame Width	"R"	"A"		"B"		"C"		"D"		"E"		Number of Rollers		WEIGHTS (Lbs.)	
			45°	30°	45°	30°	45°	30°	45°	30°	45°	30°	45°	30°	45°	30°
10"	12"	25"	23"	32"	21"	30"	21"	33"	22 11/32"	41 3/32"	50 23/32"	44 19/32"	14T/23S	20T/22S	175	189
13"	15"		26"	38"	24"	36"									189	196
16"	18"		32"	44"	30"	42"									199	212
22"	24"	32 1/2"	41"	56"	39"	54"	30"	45"	30 3/4"	55 7/32"	62 3/8"	57 3/32"	18T/29S	26T/30S	251	300

All weights in catalog are conveyor weights only. Accessories, crating, etc., are not included.

T = TAPERED
S = STRAIGHT



Model 138-NSPSS

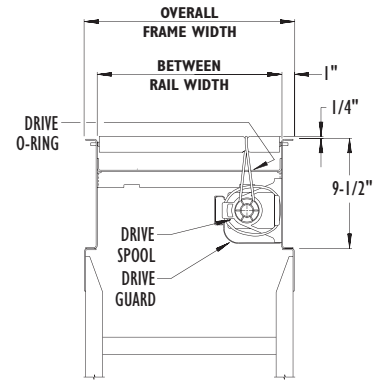
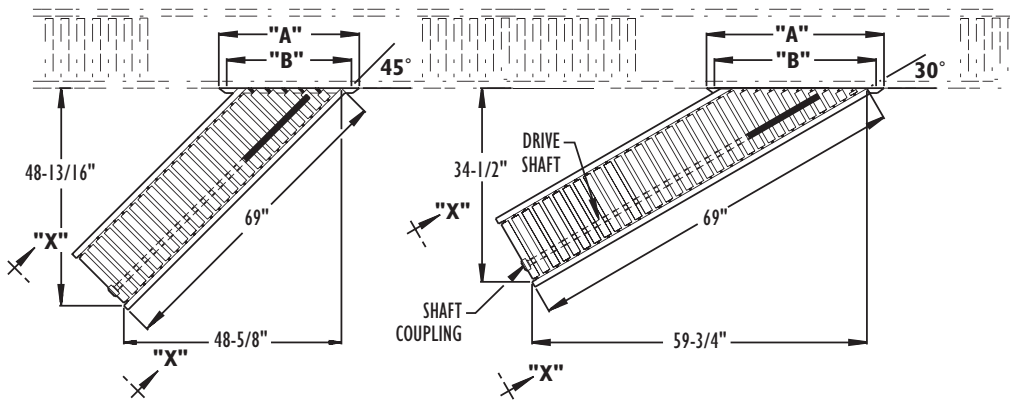

SECTION "X-X"

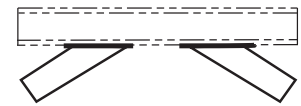

RIGHT HAND

LEFT HAND

NOTE: DARK SHAFT INDICATES POSITIVE DRIVE SPOOLS.

Between Rail Width	Overall Frame Width	"A"		"B"		WEIGHTS (Lbs.)	
		45°	30°	45°	30°	45°	30°
10"	12"	23"	32"	21"	30"	149	142
13"	15"	26"	38"	24"	36"	153	147
16"	18"	32"	44"	30"	42"	158	151
22"	24"	41"	56"	39"	54"	167	158

All weights in catalog are conveyor weights only. Accessories, crating, etc., are not included

• Standard Specifications

BED-Roller bed with 1-1/2 in. dia. tapered to 1 in. dia. x 18 ga. galvanized or 1-3/8 in. dia. roller x 18 ga. galvanized tube on 1-1/2 in. centers. Mounted in 9-1/2 in. x 12 ga. powder painted formed steel channel frame.

SLAVE DRIVEN-Curves and spurs are slave driven from drive shaft of Model 138-NSP conveyor. Shafts are coupled by chain coupling at bed joints.

DRIVE SHAFT-1 in. dia. steel shaft extends full length of conveyor, coupled with universal joints, (U joints), at necessary intervals.

DRIVE SPOOLS-2 in. dia. Delrin spool held in place on drive shaft with spool spacers.

DRIVE GUARD-Underside of drive shaft with spools and drive o-rings guarded full length of conveyor.

DRIVE O-RING-1/8 in. dia. polyurethane o-ring from drive spool to tread roller.

BEARINGS-Sealed, pre-lubricated, self-aligning, ball bearings with eccentric lock collar on drive shaft. Pre-lubricated ball bearings in tread rollers.

SPLICE PLATES-Standard for connecting to 138-NSP.

CAPACITY-225 lbs. total distributed live load.

FLOOR SUPPORTS-Now supplied as optional equipment.

• Optional Equipment

FLOOR SUPPORTS-LS Type floor supports are available with a wide range of adjustment. Specify top of belt or roller elevation. One support required at every bed joint and ends of conveyor. Holes in feet for lagging to floor. Knee braces recommended above LS-6 support.

CONVEYING SPEED-Other constant speeds from 30 to 90 FPM maximum. Capacity affected with speed change.

DRIVE-24 in. long drive section replaces standard 6-1/4 in. or 18 in. tangent on end of 138-NSPC or 138-NSPS. No change on 138-NSPSS. Specify RH or LH.

GUARD RAILS-Adjustable Universal Channel Guard Rail, fixed channel or type A or B angle. NOTE: If product comes in contact with guard rails, product flow will be affected.

POLY-TIER SUPPORTS-36 in. to 120 in. support heights in 6 in. increments. Knee braces supplied.

CEILING HANGERS-5/8 in. dia. x 8 ft. long unplated rods fully threaded. Other lengths and galvanized rods available.

OPTIONAL TANGENTS-Available in 3 in. increments up thru 48 in. long.

